

- System Design Allows Various Labeling & Coding Stations to be Added
- Equipped Standard with Ketan K50 Label Applicator (label wrap apply station)
- Apply Labels or Print onto Various Types of Round Products with Increased Accuracy
- Apply Labels Up to 4.25" In Width (Height)
- Up to 90 PPM Dependent on Product Diameter & Label Length
- Add a Top Labeler Station with Tamp & Place Labels onto the Tops of Caps with Excellent Label Placement Accuracy!
- Add a Second Applicator Station & the System will Automatically Switch Between Applicators as Labels Run Low for Increased Uptime!



Ink Jet Printer Head Mount and Coding Station

Add an ink jet printer and apply codes around the circumference of the product or integrate with label applicator & print directly on the label to be applied

Full wrap of label- excellent label placement accuracy as the product is controlled during the label application process

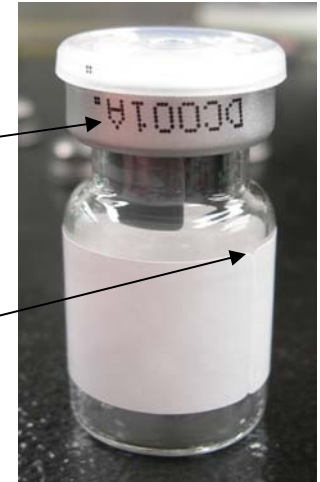

Indexes & rotates products to apply label and/or a product code around the circumference of the product

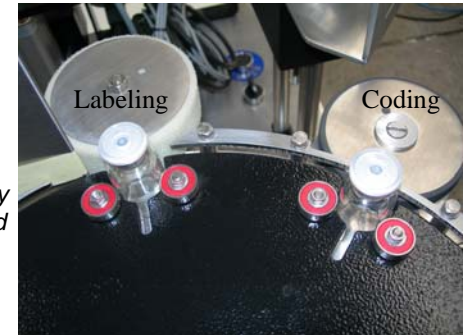

Quick change design- allows changeover to take only minutes when changing between star wheels for various diameters of products

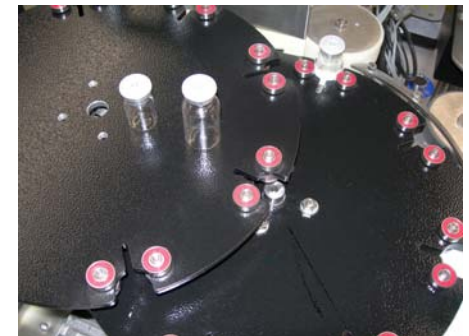

Standard Features & Specifications

- Label dispense speed up to 30 meters/min (Up to 90 BPM dependent on label length)
- Programmable Controller with LCD, product memory, counter, password protection & more
- Equipped standard with Ketan K 50 stepper driven label applicator
- Product diameters can vary- one star wheel per different diameter product will be needed
- Quick change design for star wheel change parts
- Capable of applying label widths up to 4.25"
- Stainless steel Construction
- Equipped with leveling feet & casters (Unit can be set in place or completely mobile)
- Turn handle adjust for applicator height– easily adapts for label placement on varied height products
- SWR-50 Standard unit comes with synchronized conveyance system, K50 applicator with label application station and one star wheel
- SWR-50 can be configured for use with ink jet coder only- ask Ketan representative for details
- Equipped standard with missing label on web detection

Options

- Ink jet coder integration for applying lot or expiries directly onto the label
- Ink jet coder station for applying codes directly onto circumference of products
- Hitachi Ink Jet coder for ink jet coder station or label applicator integration
- Top labeler with tamp station- apply labels to the tops of the caps as unit indexes product into place
- Second label applicator with automatic switching for Increased uptime
- Star wheel disc change parts
- Clear label sensor
- Low label sensor with three stage light beacon
- Custom integration available (ask Ketan representative for details)
- Label verification systems available (Ask Ketan representative for details)

** Some options may not be configurable with others- please consult with a Ketan representative for available configurations*

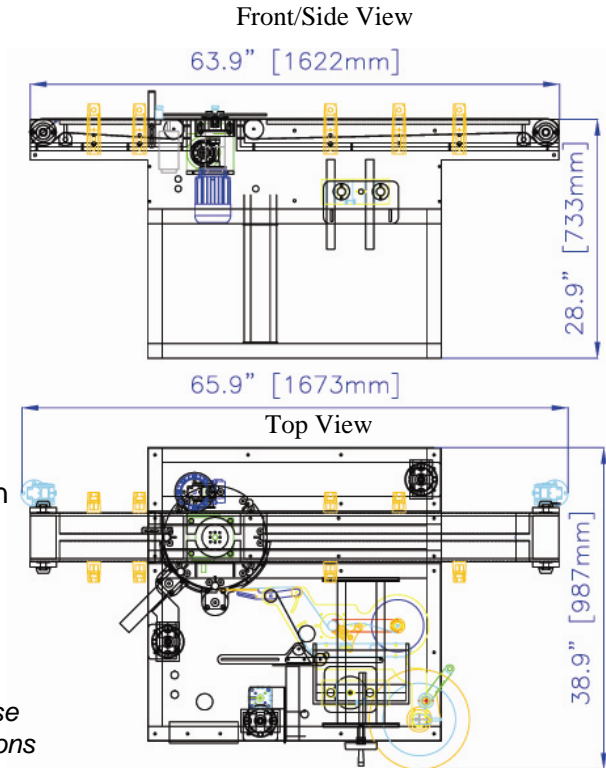

Dimensional Drawing

Electrical Requirements

115 or 220 VAC 50-60Hz
(10 amps)

Weight

350 lbs (175 kg)

Environment

32° to 115° F (0° to 46° C)

Ketan Automated Equipment, Inc. offers a wide range of coding, labeling & product handling systems for identification of products in multiple types of industries

As part of the continuing process of development Ketan reserves the right to alter the specifications and other details of its products without notice. Please ask Ketan for the latest details

Ketan Automated Equipment, Inc.

1140 E Locust Street, Suite 100, Ontario, CA 91761

Phone (909) 930-0780 Fax (909) 930-0945