

- **Stainless Steel Construction**
- **Self Synchronizing System**
- **Equipped Standard with “Automatic Label Set” Feature (reduced set up time)**



- **Up To 200 Bottles Per Minute**
- **Excellent Label Placement Accuracy**
- **Apply Labels to the Front & Back Sides of Flat or Oval Products**

Standard Features & Specifications

- Equipped standard with the “Automatic Label Set” feature for reduced set up time
- Base conveyor, top hold down drive & label dispense speed are self synchronizing
- Equipped standard with Ketan K 200 label applicators
- Capable of handling products up to 7” wide
- Maximum conveyor speed of 68 ft/min
- Min label width : 3/8” Max label width: 6.5”
- Equipped standard with X-Y & tilt adjusting label applicator base
- Remotely mountable, programmable with LCD display- label applicator controllers
- Ink Jet or Hot Stamp coder integration capabilities for printing directly onto label
- Dimensions: please see dimensional drawing
- Completely mobile system or fixed in place
- Equipped standard with adjustable guide rails
- Built in product counters on each controller
- Stainless construction
- Modular design– upgrade with any one of the Ketan accessory components at any time

Options

- Screw drives - Infeed
- Elliptical aligner –Infeed
- Product spacing - Infeed
- Saloon door tamp module– label front and both side panels
- Three stage light beacon
- Clear label sensors
- Foam rollers for secondary wipe
- Blow box modules
- Tamp modules

Electrical Requirements

115 or 220 VAC 50-60Hz (10 amps)

Weight

440 lbs (220 kg)

Environment

32° to 115° F (0° to 46° C)

Ketan Automated Equipment, Inc. offers a wide range of equipment for identification, handling, filling & induction sealing of products.

As part of the continuing process of development Ketan reserves the right to alter the specifications and other details of its products without notice. Please ask Ketan for the latest details



Excellent label placement accuracy

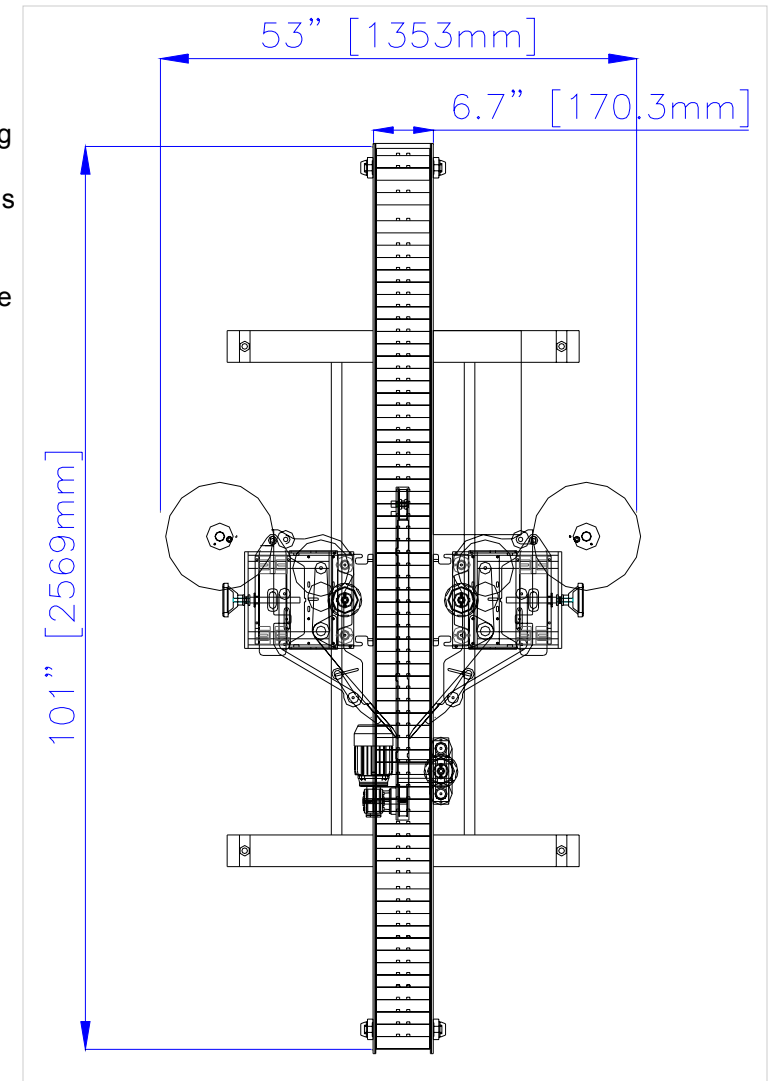

Dimensional Drawing